

Computer Numerical Control(CNC)

What is a CNC Machine?

CNC : Computerised Numerical Control (Computer + Numerical Control)

- Numerical control is a programmable automation in which process is controlled by Numbers, Letters, and symbols.
- CNC Machining is a process used in the manufacturing sector that involves the use of computers to control

machine tools like lathes, mills and grinders.

Why is CNC Machining necessary?

- To manufacture complex curved geometries in 2D or 3D was extremely expensive by mechanical means (which usually would require complex jigs to control the cutter motions)
- Machining components with high Repeatability and Precision
- Unmanned machining operations
- To improve production planning and to increase productivity
- To survive in global market CNC machines are must to achieve close tolerances.

Ball screw / ball bearing screw / recirculating balls screw Mechanism

- It consists of a screw spindle, a nut, balls and integrated ball return mechanism as shown in Figure.
- The flanged nut is attached to the moving part of CNC machine tool. As the screw rotates, the nut translates the moving part along the guide ways.

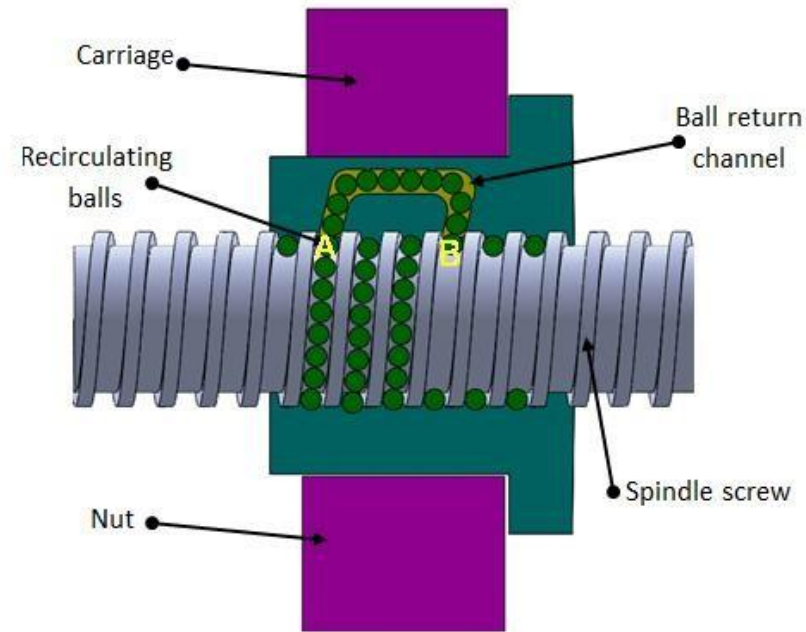

Ball Screw configuration

- However, since the groove in the ball screw is helical, its steel balls roll along the helical groove, and, then, they may go out of the ball nut unless they are arrested at a certain spot.

- Thus, it is necessary to change their path after they have reached a certain spot by guiding them, one after another, back to their “starting point” (formation of a recirculation path). The recirculation parts play that role.
- When the screw shaft is rotating, as shown in Figure, a steel ball at point (A) travels 3 turns of screw groove, rolling along the grooves of the screw shaft and the ball nut, and eventually reaches point (B).
- Then, the ball is forced to change its pathway at the tip of the tube, passing back through the tube, until it finally returns to point (A).
- Whenever the nut strokes on the screw shaft, the balls repeat the same recirculation inside the return tube.

- When debris or foreign matter enter the inside of the nut, it could affect smoothness in operation or cause premature wearing, either of which could adversely affect the ball screw's functions.
- To prevent such things from occurring, seals are provided to keep contaminants out. There are various types of seals viz. plastic seal or brush type of seal used in ball-screw drives.

Characteristics of ball screws

- **High mechanical efficiency**

In ball screws, about 90% or more of the force used to rotate the screw shaft can be converted to the force to move the ball nut.

Since friction loss is extremely low, the amount of force used to rotate the screw shaft is as low as one third of that needed for the acme thread lead screw.

- **Low in wear**

Because of rolling contact, wear is less than that of sliding contact. Thus, the accuracy is high.

Ball screws move smoothly enough under very slow speed. They run smoothly even under a load.

- **Thread Form**

The thread form used in these screws can either be gothic arc type (fig. a) or circular arc type (fig.b). The friction in this kind of arrangement is of rolling type. This reduces its wear as comparison with conventional sliding friction screws drives.

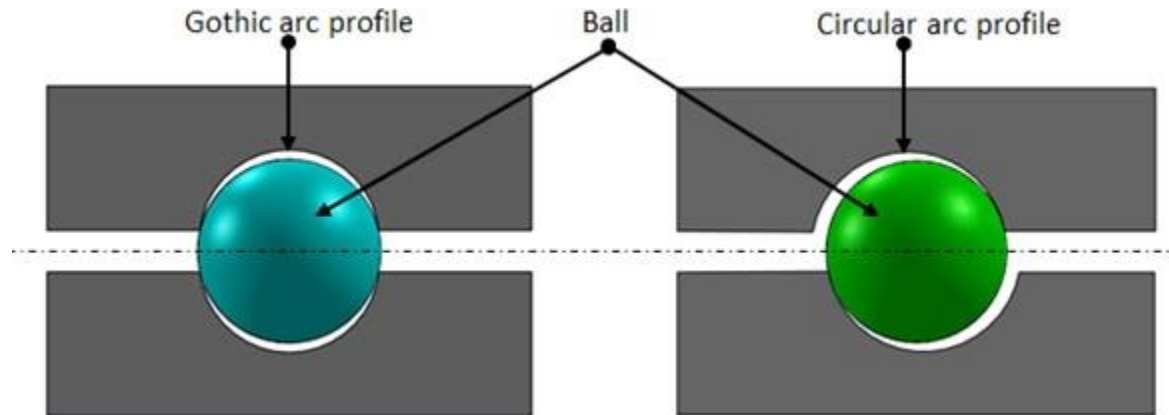

Thread forms (a) Gothic arc (b) Circular arc

Recirculating ball screws are of two types. In one arrangement the balls are returned using an external tube. In the other arrangement the balls are returned to the start of the thread in the nut through a channel inside the nut.

- **Preloading**

In order to obtain bidirectional motion of the carriage without any positional error, the backlash between the nut and screw should be minimum.

Zero backlash can be obtained by fitting two nuts with preloading (tension or compression) or by applying a load which exceeds the maximum operating load.

Figure shows double nut preloading system. A shim plate (spacer) is inserted between two nuts for preloading. Preload is to create elastic deformations (deflections) in steel balls and Ball grooves in the nut and the screw shaft in advance by providing an axial load.

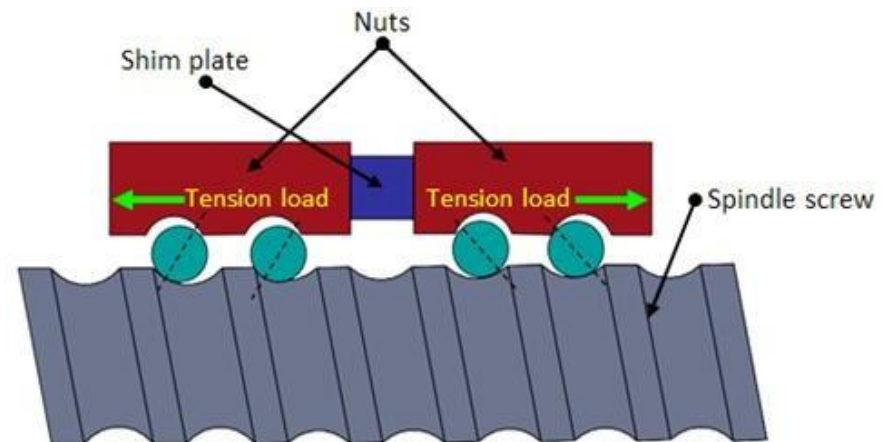

Double nut preloading system

As a result the balls in one of the nuts contact the one side of the thread and balls in the other nut contact the opposite side.

Effects of preload

- Zero backlash: It eliminates axial play between a screw shaft and a ball nut.
- It minimizes elastic deformation caused by external force, thus The rigidity enhances.
- In case mounting errors, misalignment between the screw shaft and the nut may occur this further generates distortion forces.
- This could lead to the problems such as,
 - Shortened service life
 - Adverse effect on smooth operation
 - Reduced positioning accuracy
 - Generation of noise or vibration
 - Breakage of screw shaft

Advantages of ball screws

- Highly efficient and reliable.
- Less starting torque.
- Lower coefficient of friction compared to sliding type screws and run at cooler temperatures
- Power transmission efficiency is very high and is of the order of 95 %.
- Could be easily preloaded to eliminate backlash.
- The friction force is virtually independent of the travel velocity and the friction at rest is very small; consequently, the stick-slip phenomenon is practically absent, ensuring uniformity of motion.
- Has longer thread life hence need to be replaced less frequently.
- Ball screws are well -suited to high through output, high speed applications or those with continuous or long cycle times.
- Smooth movement over full range of travel.

Disadvantages of ball screws

- Tend to vibrate.
- Require periodic overhauling to maintain their efficiency.
- Inclusion of dirt or foreign particles reduces the life of the screws.
- Not as stiff as other power screws, thus deflection and critical speed can cause difficulties.
- They are not self-locking screws hence cannot be used in holding devices such as vices.
- Require high levels of lubrication.

Applications of ball screws

- Ball screws are employed in cutting machines, such as machining center and NC lathe where accurate positioning of the table is desired
- Used in the equipment's such as lithographic equipment or inspection apparatus where precise positioning is vital
- High precision ball screws are used in steppers for semiconductor manufacturing industries for precision assembly of micro parts.
- Used in robotics application where precision positioning is needed.
- Used in medical examination equipment's since they are highly accurate and provide smooth motion.

DIFFERENCES BETWEEN CNC MACHINES TOOLS AND CONVENTIONAL MACHINE TOOLS

➤ **Constructional details:**

- Basically conventional machine have 2 axes, known as X & Y axis.
- There is also a Z axis long which only the bed moves vertically.
- The spindle along with the tool does not move as it is fixed with the machine body .

But in case of CNC machine, there are minimum 3 axes with Spindle moving parallel to Z axis.

- CNC machines have more rigid construction when compared to the conventional machine.
- The slide ways, guide and spindles of the CNC machine all look over proportioned when compared to the conventional machine.

The structure of the CNC machine is therefore designed to cope with the torsional forces and heavy duty cutting imposed on these machines.

➤ Recirculating ball lead screws and anti friction slide ways

CONVENTIONAL

- The slide ways on a conventional machine operate under the conditions of sliding friction.
- The lead screws are usually of the Acme thread form, which are inefficient due to the high frictional resistance between the flanks of the screw and the nut. There is also backlash, because of the clearance between the screw and the nut.

CNC

- Rolling friction can be used instead of sliding friction, where re-circulating roller bearings are positioned under the slide ways.
- A recirculating ball lead screw, where both the lead screw and the nut have a precision ground radiused shaped thread. The space or track between the lead screw and nut is filled with an endless stream of ball bearings.

The advantages are longer life, less frictional resistance, lower torque required, more precise positioning of slides, where backlash is almost completely eliminated.

➤ Use of Stepping Motors in Slide Movement

The slides and spindle of the CNC machine are driven by stepper motors.

STEPPER MOTOR – A digital signal is sent from the controller to the motor in the form of pulses, which will cause the motor to rotate through a specified angle, which causes the slide to move by the required distance.

Example:

If five digital pulses are sent to the stepper motor then it will rotate by five steps, which is converted to linear movement by the lead screw. The speed by which the pulses are sent to the stepper motor will determine the velocity of the slide movement. As the distance moved by the slide and the feed can be accurately controlled by the CNC control system, there is no need for positional or velocity feedback

MAJOR COMPONENTS RELATED TO CNC MACHINE TOOLS

Any CNC machine tool essentially consists of the following parts:

□ Part program:

- A series of coded instructions required to produce a part.
- Controls the movement of the machine tool and on/off control of auxiliary functions such as spindle rotation and coolant.
- The coded instructions are composed of letters, numbers and symbols.

□ Program input device

- The program input device is the means for part program to be entered into the CNC control.
- Three commonly used program input devices are punch tape reader, magnetic tape reader, and computer via RS-232-C communication.

□ Machine Control Unit

The machine control unit (MCU) is the heart of a CNC system. It is used to perform the following functions:

- To read the coded instructions.
- To decode the coded instructions.
- To implement interpolations (linear, circular, and helical) to generate axis motion commands.
- To feed the axis motion commands to the amplifier circuits for driving the axis mechanisms.
- To receive the feedback signals of position and speed for each drive axis.
- To implement auxiliary control functions such as coolant or spindle on/off and tool change.

□ Machine Tool

- CNC controls are used to control various types of machine tools.
- Regardless of which type of machine tool is controlled, it always has a slide table and a spindle to control position and speed.
- The machine table is controlled in the X and Y axes, while the spindle runs along the Z axis.

□ **Feed Back System**

- The feedback system is also referred to as the measuring system.
- It uses position and speed transducers to continuously monitor the position at which the cutting tool is located at any particular instant.
- The MCU uses the difference between reference signals and feedback signals to generate the control signals for correcting position and speed errors.

□ Drive System

- Drives are used to provide controlled motion to CNC elements
- A drive system consists of amplifier circuits, drive motors, and ball lead-screws.
- The MCU feeds the control signals (position and speed) of each axis to the amplifier circuits.
- The control signals are augmented to actuate drive motors which in turn rotate the ball lead-screws to position the machine table.

➤ POWER DRIVES

- In machine tools, power is generally required for driving the main spindle, saddles and carriages and to some auxiliary units.
- The motors used for CNC system are of two kinds
 - ✓ Electrical - AC , DC or Stepper motors
 - ✓ Fluid - Hydraulic or Pneumatic
- In CNC, usually stepper and servo electrical drives are used
- They exhibit favourable torque-speed characteristics and are relatively inexpensive.

✓ **STEPPER MOTOR**

A stepper motor is a pulse-driven motor that changes the angular position of the rotor in steps.

Due to this nature of a stepper motor, it is widely used in low cost, open loop position control systems.

Types of stepper motors:

- Permanent Magnet

 - Employ permanent magnet

 - Low speed, relatively high torque

- Variable Reluctance

 - Does not have permanent magnet

 - Low torque

Permanent magnet (PM) stepper motor

- Rotor is a permanent magnet.
- PM motor rotor has no teeth and is designed to be magnetized at a right angle to its axis.
- Figure shows a simple, 90° PM motor with four phases (A-D).
- Applying current to each phase in sequence will cause the rotor to rotate by adjusting to the changing magnetic fields.
- Although it operates at fairly low speed, the PM motor has a relatively high torque characteristic.
- These are low cost motors with typical step angle ranging between 7.5° to 15°

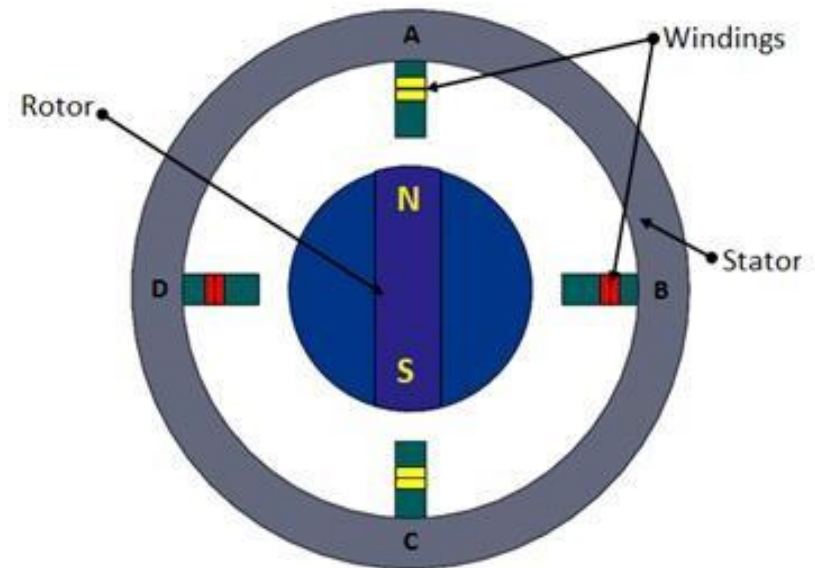

Permanent magnet stepper

Variable Reluctance Motor

- The cylindrical rotor is made of soft steel and has four poles
- It has four rotor teeth, 90° apart and six stator poles, 60° apart.
- Electromagnetic field is produced by activating the stator coils in sequence.
- It attracts the metal rotor. When the windings are energized in a reoccurring sequence of 2, 3, 1, and so on, the motor will rotate in a 30° step angle.
- In the non-energized condition, there is no magnetic flux in the air gap, as the stator is an electromagnet and the rotor is a piece of soft iron; hence, there is no detent torque.

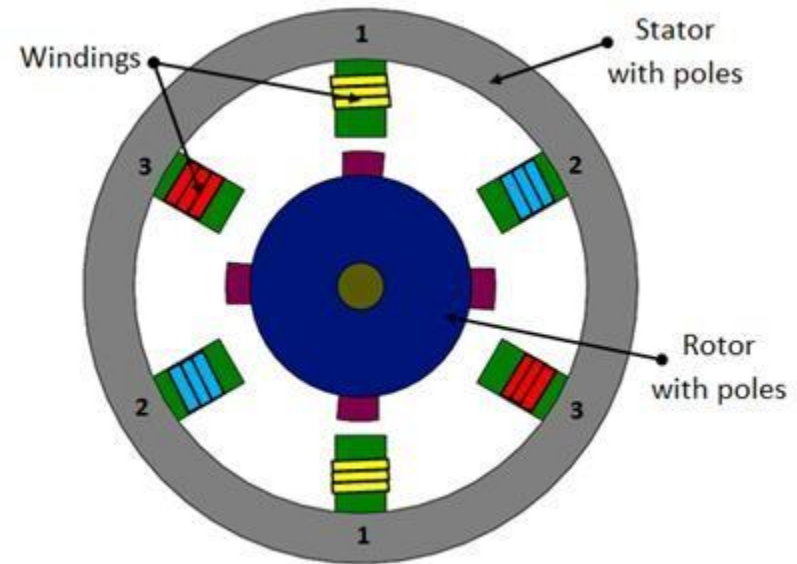
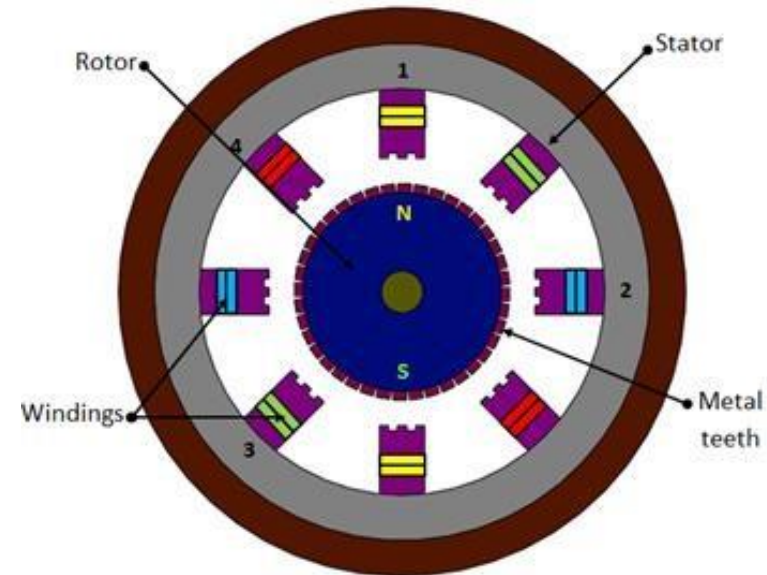

Fig. Variable reluctance stepper motor

Hybrid stepper motor

- Hybrid stepping motors combine a permanent magnet and a rotor with metal teeth to provide features of the variable reluctance and permanent magnet motors together.
- The number of rotor pole pairs is equal to the number of teeth on one of the rotor's parts. The hybrid motor stator has teeth creating more poles than the main poles windings



Hybrid stepper

- Rotation of a hybrid stepping motor is produced in the similar fashion as a permanent magnet stepping motor, by energizing individual windings in a positive or negative direction.
- When a winding is energized, north and south poles are created, depending on the polarity of the current flowing.
- These generated poles attract the permanent poles of the rotor and also the finer metal teeth present on rotor.

- The rotor moves one step to align the offset magnetized rotor teeth to the corresponding energized windings.
- Hybrid motors are more expensive than motors with permanent magnets, but they use smaller steps, have greater torque and maximum speed.
- Step angle of a stepper motor is given by,

$$\text{Step angle} = \frac{360^{\circ}}{\text{number of poles}}$$

Advantages of stepper motors

- Low cost
- Ruggedness
- Simplicity of construction
- Low maintenance
- Less likely to stall or slip
- Will work in any environment
- Excellent start-stop and reversing responses

Disadvantages of stepper motors

- Low torque capacity compared to DC motors
- Limited speed
- During overloading, the synchronization will be broken. Vibration and noise occur when running at high speed.

✓ SERVO MOTORS

- Servomotors are special electromechanical devices that produce precise degrees of rotation.
- A servo motor is a DC or AC or brushless DC motor combined with a position sensing device.
- Servomotors are also called control motors as they are involved in controlling a mechanical system.
- The servomotors are used in a closed-loop servo system as shown in Figure A reference input is sent to the servo amplifier, which controls the speed of the servomotor.

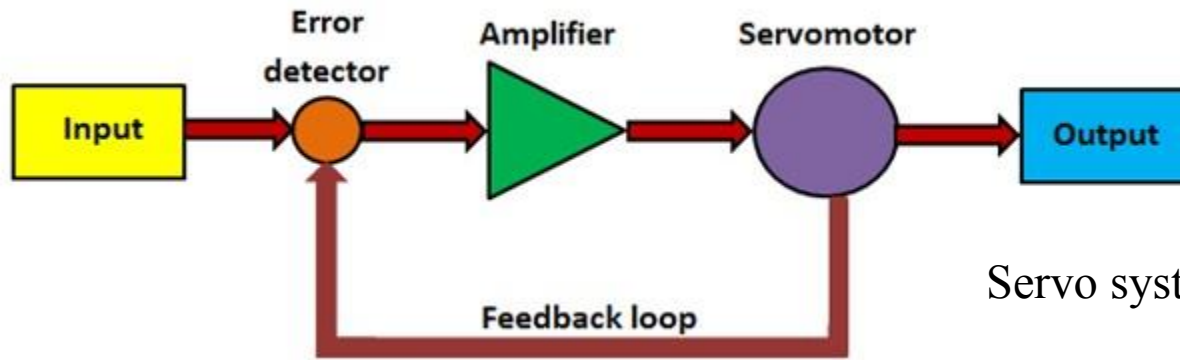

Servo system block diagram

- A feedback device is mounted on the machine, which is either an encoder or resolver.
- This device changes mechanical motion into electrical signals and is used as a feedback.
- This feedback is sent to the error detector , which compares the actual operation with that of the reference input.
- If there is an error, that error is fed directly to the amplifier, which will be used to make necessary corrections in control action.

- In many servo systems, both velocity and position are monitored.
- Servomotors provide accurate speed, torque, and have ability of direction control.

DC servomotors

DC operated servomotors are usually respond to error signal abruptly and accelerate the load quickly. A DC servo motor is actually an assembly of four separate components, namely:

- DC motor
- gear assembly
- position-sensing device
- control circuit

AC servo motor

- Magnetic force is generated by a permanent magnet and current which further produce the torque.
- It has no brushes so there is little noise/vibration. This motor provides high precision control with the help of high resolution encoder.
- The stator is composed of a core and a winding. The rotor part comprises of shaft, rotor core and a permanent magnet.
- Digital encoder can be of optical or magnetic type. It gives digital signals, which are in proportion of rotation of the shaft.

Advantages of servo motors

- Provides high intermittent torque, high torque to inertia ratio, and high speeds
- Work well for velocity control
- Available in all sizes
- Quiet in operation
- Smoother rotation at lower speeds

Disadvantages of servo motors

- More expensive than stepper motors
- Require tuning of control loop parameters
- Not suitable for hazardous environments or in vacuum
- Excessive current can result in partial demagnetization of DC type servo motor

➤ LINEAR MOTION DRIVES

- Linear motion drives are mechanical transmission systems which are used to convert rotary motion into linear motion.
- The conventional thread forms like vee or square are not suitable in CNC because of their high wear and less efficiency.
- Therefore CNC machines generally employ ball screw for driving their workpiece carriages.
- These drives provide backlash free operation with low friction-wear characteristics.
- These are efficient and accurate in comparison with that of nut-and-screw drives. Most widely used linear motion drives are ball screws.

PART PROGRAMMING

INTRODUCTION

A group of commands given to the CNC for operating the machine is called the program.

It consists of:

- Information about part geometry
- Motion statements to move the cutting tool
- Cutting speed
- Feed
- Auxiliary functions such as coolant on and off, spindle direction

□ CNC program structure

There are four basic terms used in CNC programming
Character -> Word -> Block -> Program

- Character is the smallest unit of CNC program. It can have Digit / Letter / Symbol.
- Word is a combination of alpha-numerical characters. This creates a single instruction to the CNC machine. Each word begins with a capital letter, followed by a numeral. These are used to represent axes positions, federate, speed, preparatory commands, and miscellaneous functions.
- A program block may contain multiple words, sequenced in a logical order of processing.
- The program comprises of multiple lines of instructions, „blocks“ which will be executed by the machine control unit (MCU).

FIXED ZERO v/s FLOATING ZERO

Fixed zero:

- Origin is always located at some position on M/C table (usually at south west corner/Lower left-hand) of the tables & all tool location are defined W.R.T. this zero

Floating Zero:

- Very common with CNC M/C used now a days.
- Operator sets zero point at any convenient position on M/C table.
- The Coordinate system is known as work coordinate system (WCS)

Modal and Non modal commands

- Commands issued in the NC program may stay in **effect indefinitely** (until they explicitly cancelled or changed by some other command), or they may be effective for only the one time that they are issued.
- The former are referred as **Modal commands**. Examples include feed rate selection and coolant selection.
- Commands that are **effective only when issued** and whose effects are lost for subsequent commands are referred to as **non-modal commands**.
- A dwell command, which instructs the tool to remain in a given configuration for a given amount of time, is an example of a non-modal command.

Structure of an NC part program

- An NC part program is made up of a series of commands that are input into the MCU in a serial manner.
- The MCU interprets these commands and generates the necessary signals to each of the drive units of the machine to accomplish the required action.
- The NC program is required to have a particular structure that the controller can understand and it must follow a specific syntax.
- Commands are inputs into the controller in units called blocks or statements.
- Each block is made up of one or more machine commands.

- In general, several commands are grouped together to accomplish a specific machining operation, hence the use of a block of information for each operation.
- Each command gives a specific element of control data, such as dimension or a feed rate. Each command within a block is also called a word.
- The way in which words are arranged within the block is called block format.
- Three different block formats are commonly used, (Fixed sequential format, Tab sequential format and Word address format)

Word Sequential Format : Used on virtually all modern controllers.

```
N50 G00 X50 Y25 Z0 F0  
N60 G01 Z-1 F50 M08  
N70 Z0 M09
```

- With this type of format, each type of word is assigned as address that is identified by a letter code within the part program.
- Thus the letter code specifies the type of word that follows and then its associated numeric data is given.
- For example, the code T represents a tool number. Thus a word of the form T01 would represent tool number 1.
- Theoretically, with this approach, the words in a given block can be entered in any sequence and the controller should be able to interpret them correctly.

- With the word address format only the needed words for a given operation have to be included within the block.
- The command to which the particular numeric data applies is identified by the preceding address code.
- Word format has the advantage of having more than one particular command in one block something that would be impossible in the other two formats.

COMMONLY USED WORD ADDRESSES

- **N-CODE**: Sequence number, used to identify each block within an NC program and provides a means by which NC commands may be rapidly located. It is program line number. It is a good practice to increment each block number by 5 to 10 to allow additional blocks to be inserted if future changes are required.
- **G-CODE**: Preparatory Word, used as a communication device to prepare the MCU. The G-code indicates that a given control function such as G01, linear interpolation, is to be requested.
- **X, Y & Z-CODES**: Coordinates. These give the coordinate positions of the tool.

- **F-CODE**: Feed rate. The F code specifies the feed in the machining operation.
- **S-CODE**: Spindle speed. The S code specifies the cutting speed of the machining process.
- **T-CODE**: Tool selection. The T code specifies which tool is to be used in a specific operation.
- **M-CODE**: Miscellaneous function. The M code is used to designate a particular mode of operation for an NC machine tool.
- **I, J & K-CODES**: They specify the centre of arc coordinates from starting.

Sequence and format of words:

N3 G2 X+1.4 Y+1.4 Z+1.4 I2.0 J2.0 K2.0 F5 S4 T4 M2

sequence no

destination coordinates

preparatory function

dist to center of circle

feed rate

spindle speed

tool

Other function

G00	Rapid Linear Positioning	G55	Work Coordinate System 2 Selection
G01	Linear Feed Interpolation	G56	Work Coordinate System 3 Selection
G02	CW Circular Interpolation	G57	Work Coordinate System 4 Selection
G03	CCW Circular Interpolation	G58	Work Coordinate System 5 Selection
G04	Dwell	G59	Work Coordinate System 6 Selection
G07	Imaginary Axis Designation	G60	Single Direction Positioning
G09	Exact Stop	G61	Exact Stop Mode
G10	Offset Value Setting	G64	Cutting Mode
G17	XY Plane Selection	G65	Custom Macro Simple Call
G18	ZX Plane Selection	G66	Custom Macro Modal Call
G19	YZ plane Selection	G67	Custom Macro Modal Call Cancel
G20	Input In Inches	G68	Coordinate System Rotation On
G21	Input In Millimeters	G69	Coordinate System Rotation Off
G22	Stored Stroke Limit On	G73	Peck Drilling Cycle
G23	Stored Stroke Limit Off	G74	Counter Tapping Cycle
G27	Reference Point Return Check	G76	Fine Boring
G28	Return To Reference Point	G80	Canned Cycle Cancel
G29	Return From Reference Point	G81	Drilling Cycle, Spot Boring
G30	Return To 2nd, 3rd and 4th Ref. Point	G82	Drilling Cycle, Counter Boring
G31	Skip Cutting	G83	Peck Drilling Cycle
G33	Thread Cutting	G84	Tapping Cycle
G40	Cutter Compensation Cancel	G85	Boring Cycle
G41	Cutter Compensation Left	G86	Boring Cycle
G42	Cutter Compensation Right	G87	Back Boring Cycle
G43	Tool Length Compensation + Direction	G88	Boring Cycle
G44	Tool Length Compensation - Direction	G89	Boring Cycle
G45	Tool Offset Increase	G90	Absolute Programming
G46	Tool Offset Double	G91	Incremental Programming
G47	Tool Offset Double Increase	G92	Programming Of Absolute Zero
G48	Tool Offset Double Decrease	G94	Feed Per Minute
G49	Tool Length Compensation Cancel	G95	Feed Per Revolution
G50	Scaling Off	G96	Constant Surface Speed Control
G51	Scaling On	G97	Constant Surface Speed Control Cancel
G52	Local Coordinate System Setting	G98	Return To Initial Point In Canned Cycles
G54	Work Coordinate System 1 Selection	G99	Return To R Point In Canned Cycles

List of M codes

M codes vary from machine to machine depending on the functions available on it. They are decided by the manufacturer of the machine. The M codes listed below are the common ones.

M-codes	Function
M00	Optional program stop automatic
M01	Optional program stop request
M02	Program end
M03	Spindle ON clock wise (CW)
M04	Spindle ON counter clock wise (CCW)
M05	Spindle stop
M06	Tool change
M07	Mist coolant ON (coolant 1 ON)
M08	Flood coolant ON (coolant 2 ON)
M09	Coolant OFF
M30	End of program, Reset to start
M98	Sub program call
M99	Sub program end

G00 Rapid traverse

When the tool being positioned at a point preparatory to a cutting motion, to save time it is moved along a straight line at Rapid traverse, at a fixed traverse rate which is pre-programmed into the machine's control system.

Typical rapid traverse rates are 10 to 25 m /min., but can be as high as 80 m/min.

Syntax: N010 [G90/G91] G00 X10 Y10 Z5

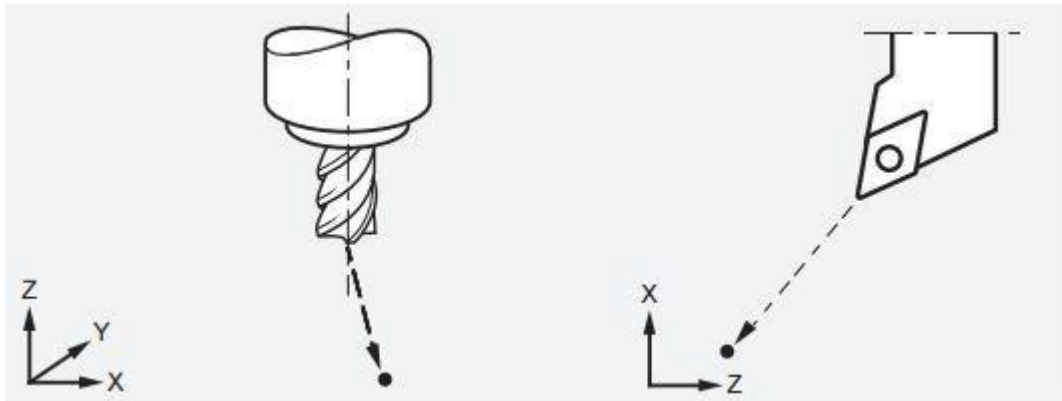

G01 Linear interpolation (feed traverse)

The tool moves along a straight line in one or two axis simultaneously at a programmed linear speed, the feed rate.

Syntax: N010[G90/G91] G01 X10 Y10 Z5 F25

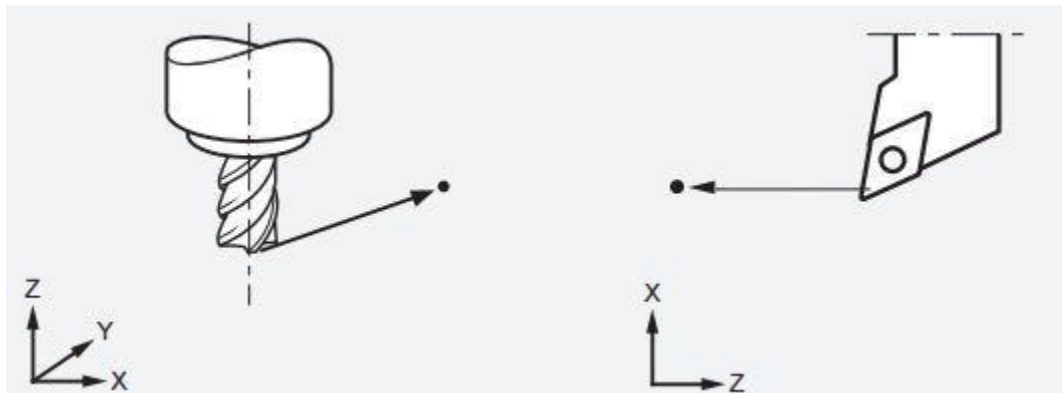

G02/G03 Circular interpolation

Format

N__G02/03 X__Y__Z__ I__J__K__F__ using the arc center

or

N__G02/03 X__Y__Z__ R__F__ using the arc radius

Arc center

The arc center is specified by addresses I, J and K. I, J and K are the X, Y and Z co-ordinates of the arc center with reference to the arc start point.

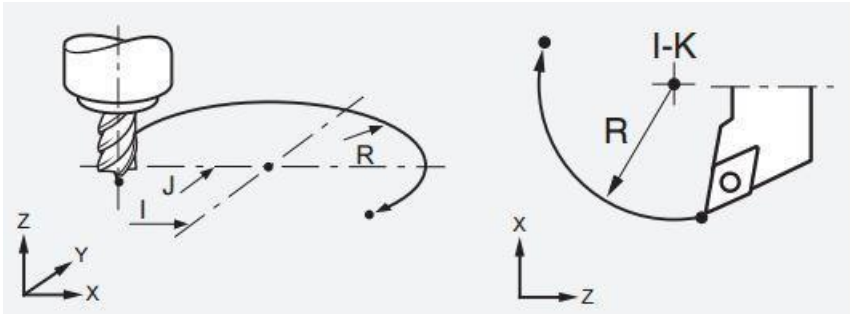

G02 moves along a CW arc

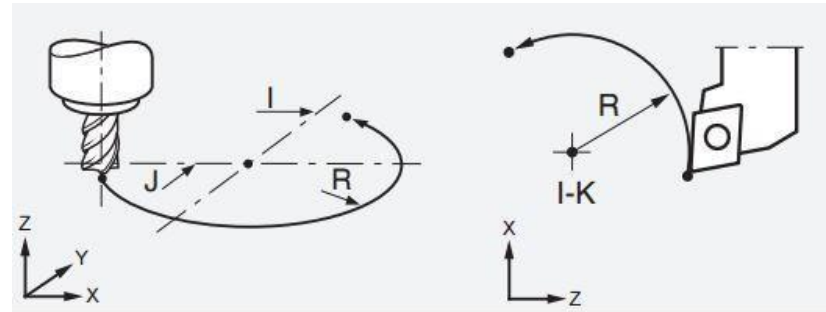

G03 moves along a CCW arc

G90 ABSOLUTE POSITION COMMAND

- When using a G90 absolute position command, each dimension or move is referenced from a fixed point, known as ABSOLUTE ZERO (part zero).
- Absolute zero is usually set at the corner edge of a part, or at the center of a square or round part, or an existing bore. ABSOLUTE ZERO is where the dimensions of a part program are defined from.
- Absolute dimensions are referenced from a known point on the part, and can be any point the operator chooses, such as the upper-left corner, center of a round part, or an existing bore.

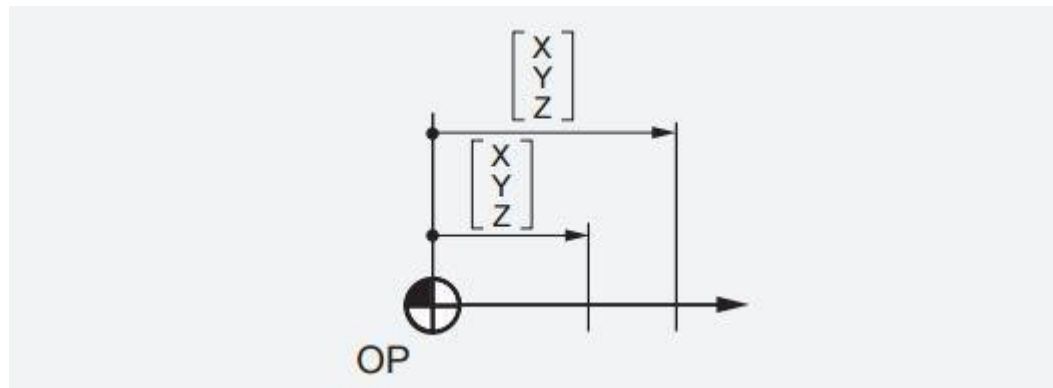

Syntax: N.. G90 X.. Y.. Z.. A.. B.. C..

G91 INCREMENTAL POSITION COMMAND

- This code is modal and changes the way axis motion commands are interpreted. G91 makes all subsequent commands incremental. Zero point shifts with the new position.

Syntax: N.. G91 X.. Y.. Z.. A.. B.. C..

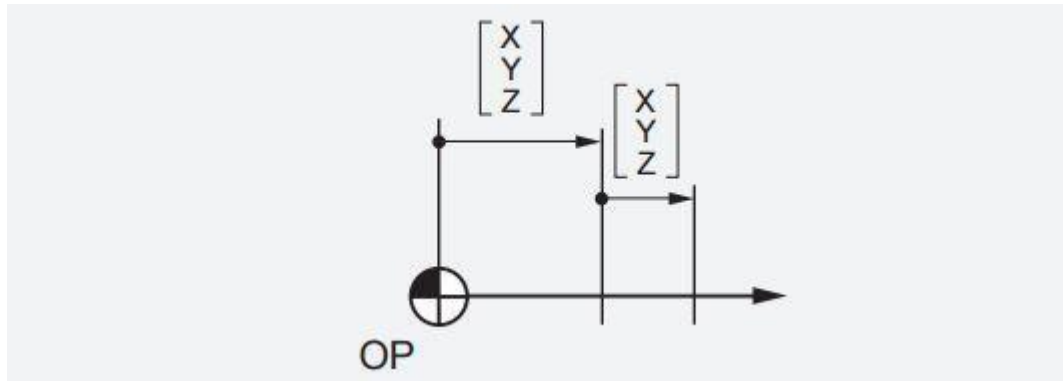

G 17 G18 G19 : PLANE SELECTION

G 17 : XY plane
selection Syntax: N..
G17

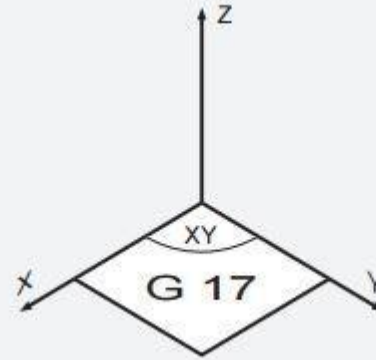

G 18 : ZX plane
selection Syntax: N..
G18

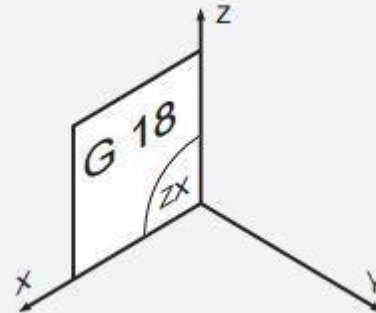

G 19 : ZY plane
selection Syntax: N..
G19

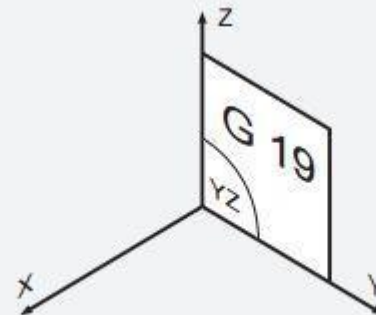

Syntax: N020 G17 G75 F6.0 S300 T1001 M08

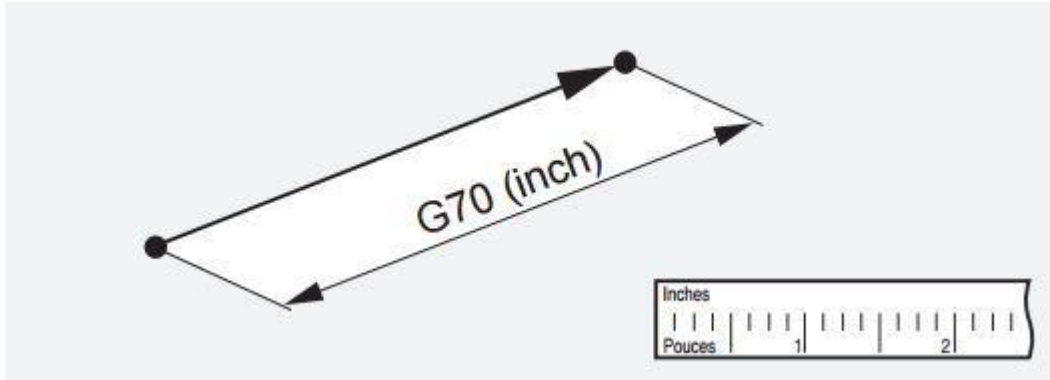

G 70 Inch data input

G 71 Metric data input

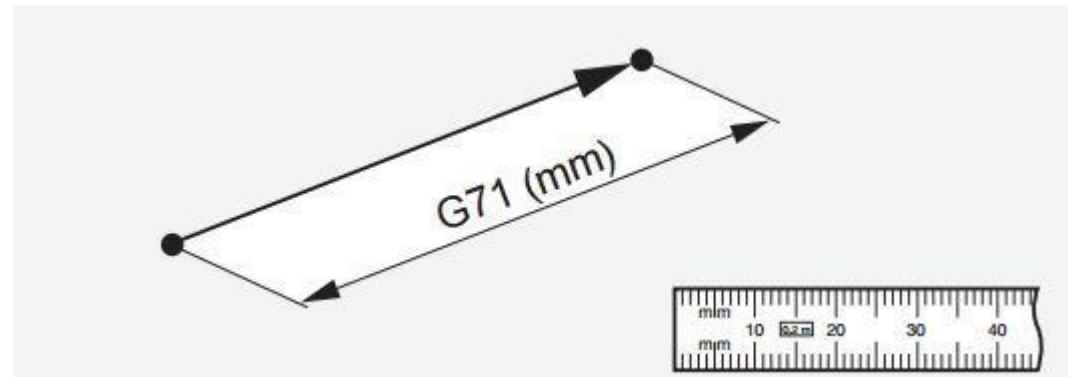

Syntax : N010 G70 G90 G94 G97 M04

Manual Part Programming Example

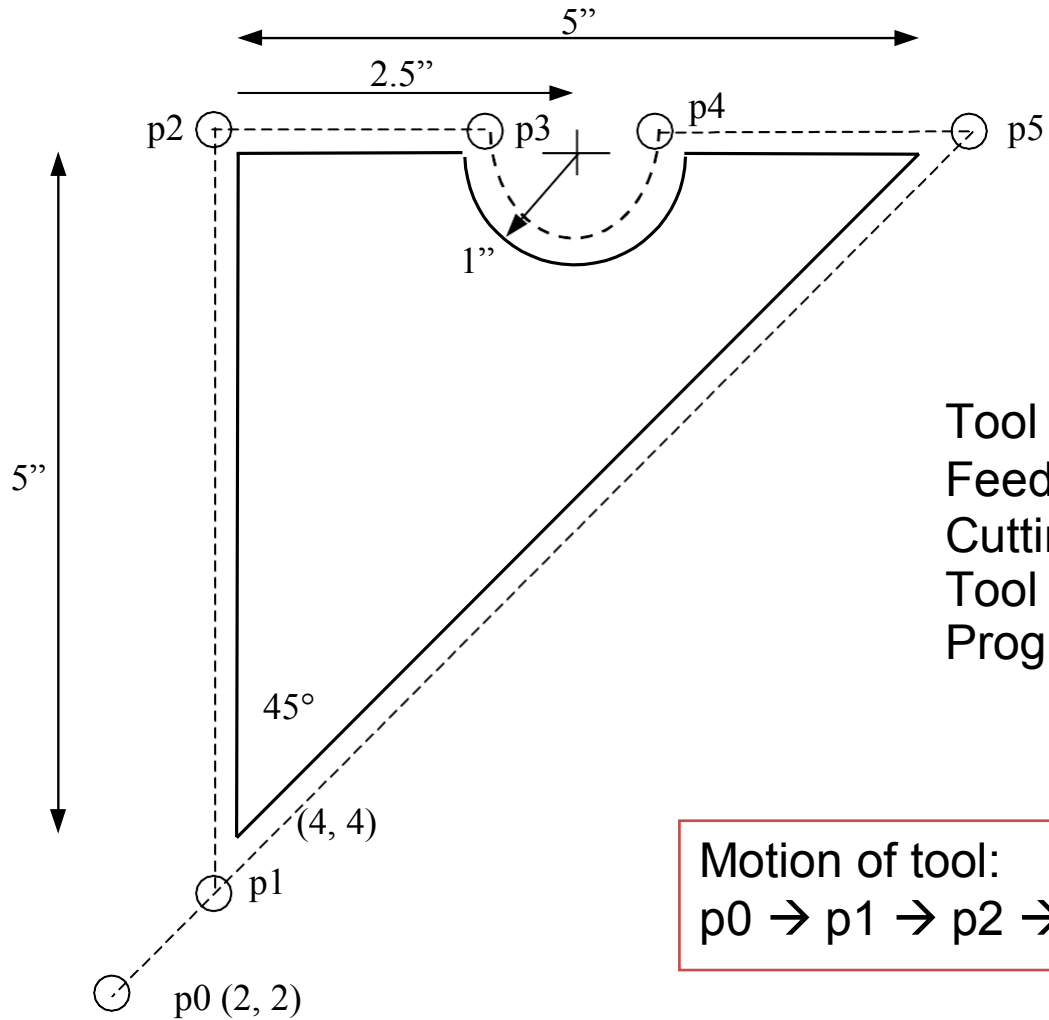

Tool size = 0.25 inch,
Feed rate = 6 inch per minute,
Cutting speed = 300 rpm,
Tool start position: 2.0, 2.0
Programming in inches

Motion of tool:
p0 → p1 → p2 → p3 → p4 → p5 → p1 → p0

1. Set up the programming parameters

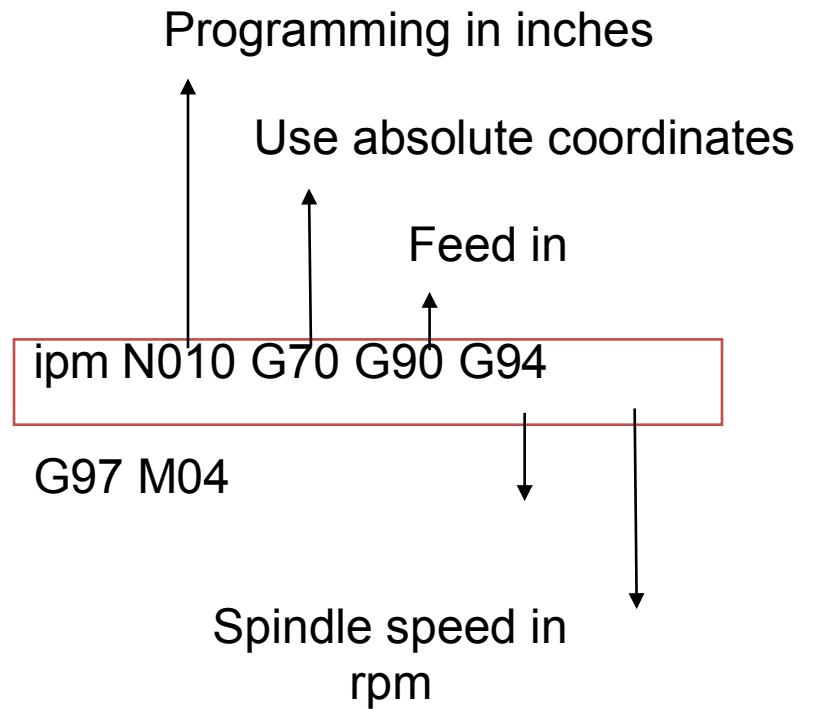
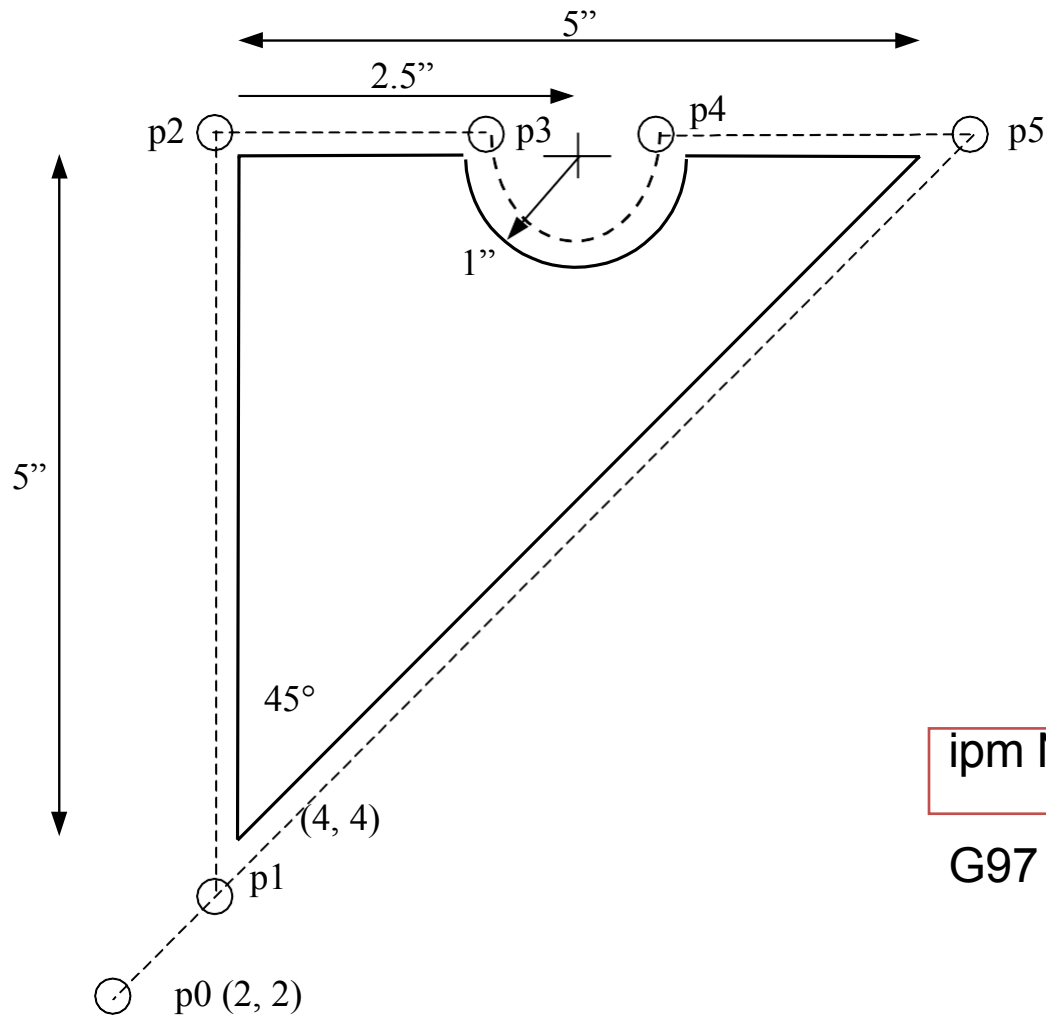

S
p
i
n
d
l
e

C
C
W

2. Set up the machining conditions

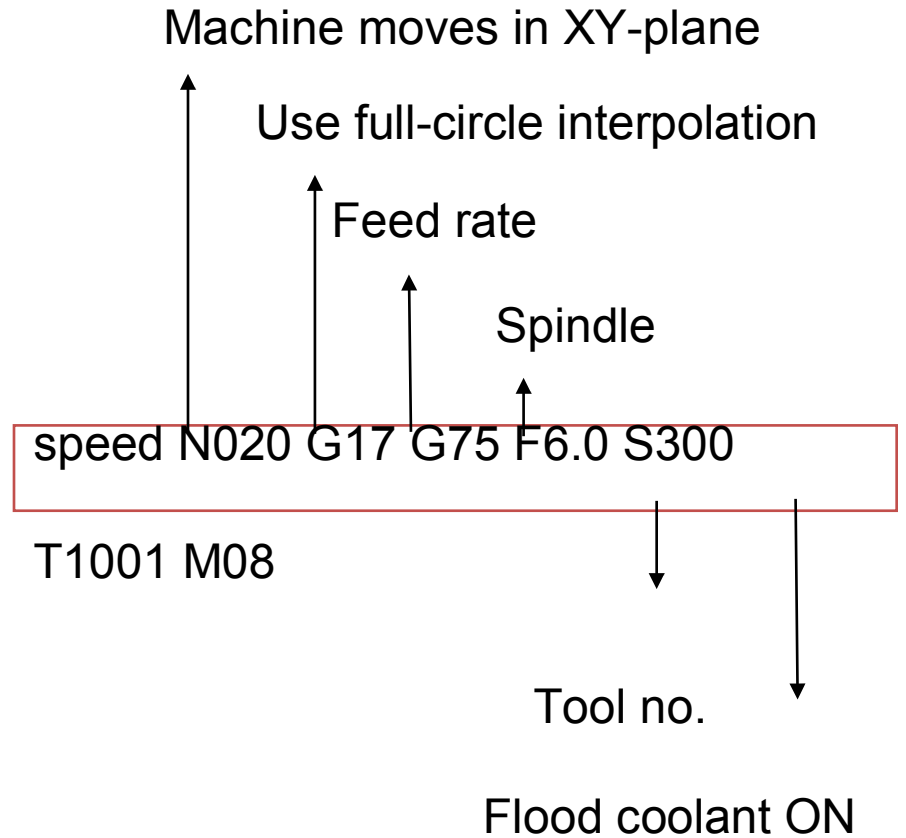
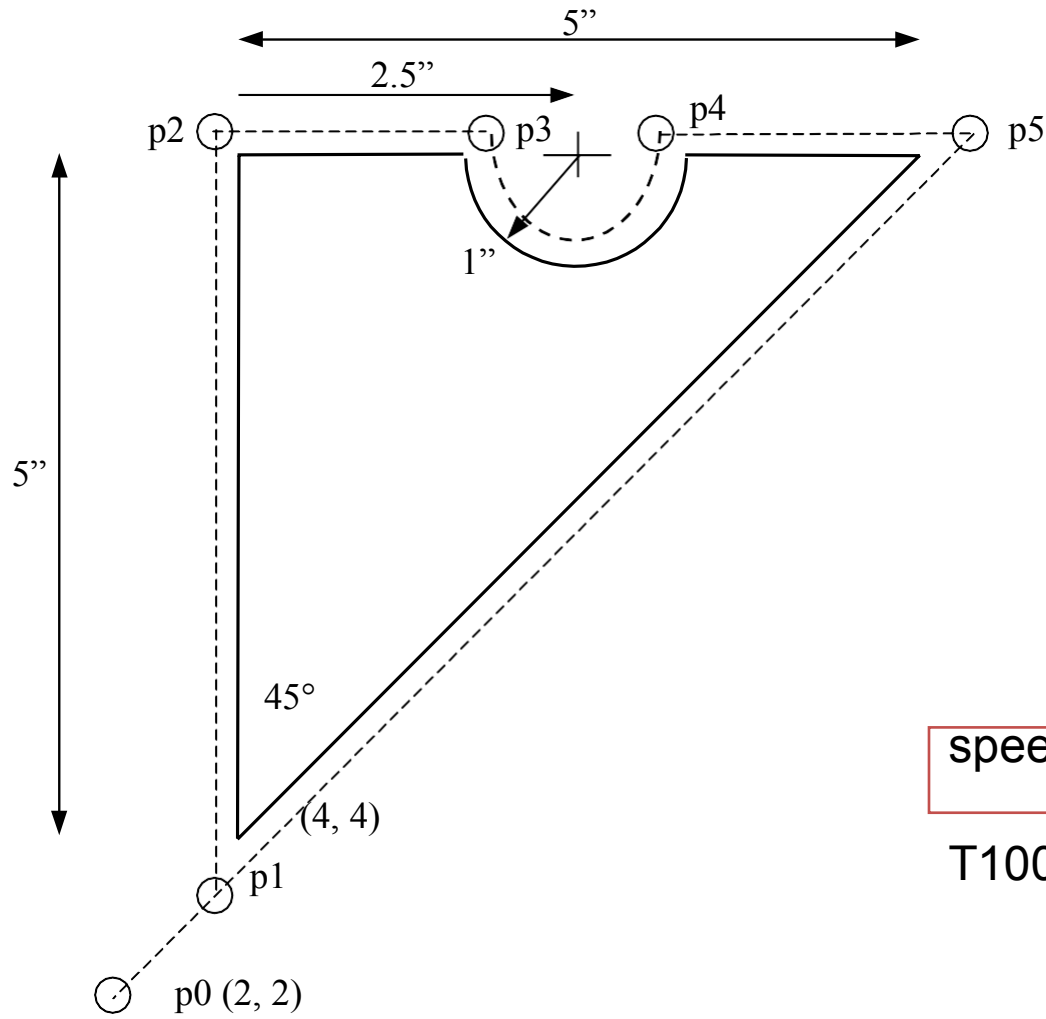

3. Move tool from p0 to p1 in straight line

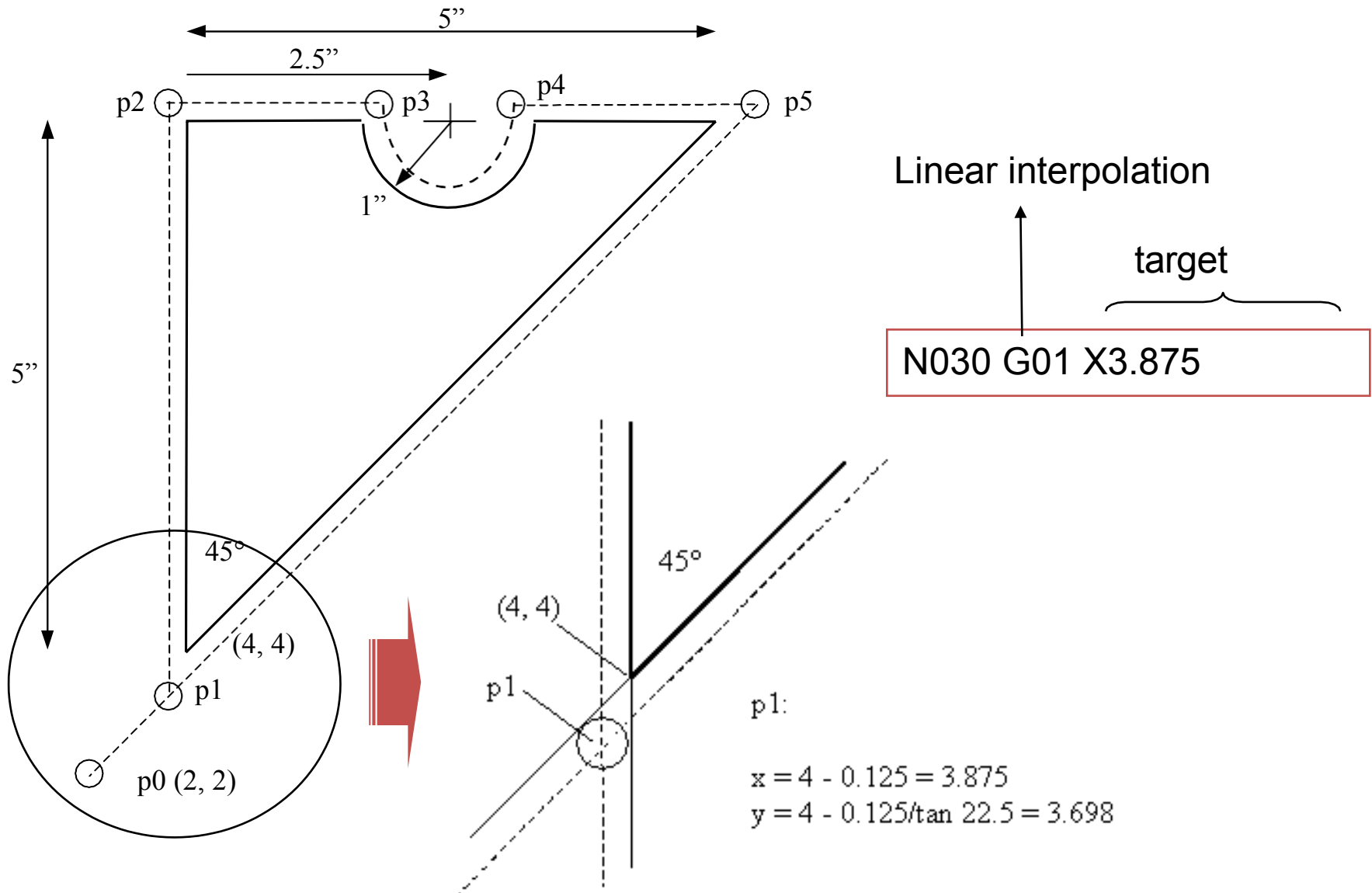

4. Cut profile from p1 to p2

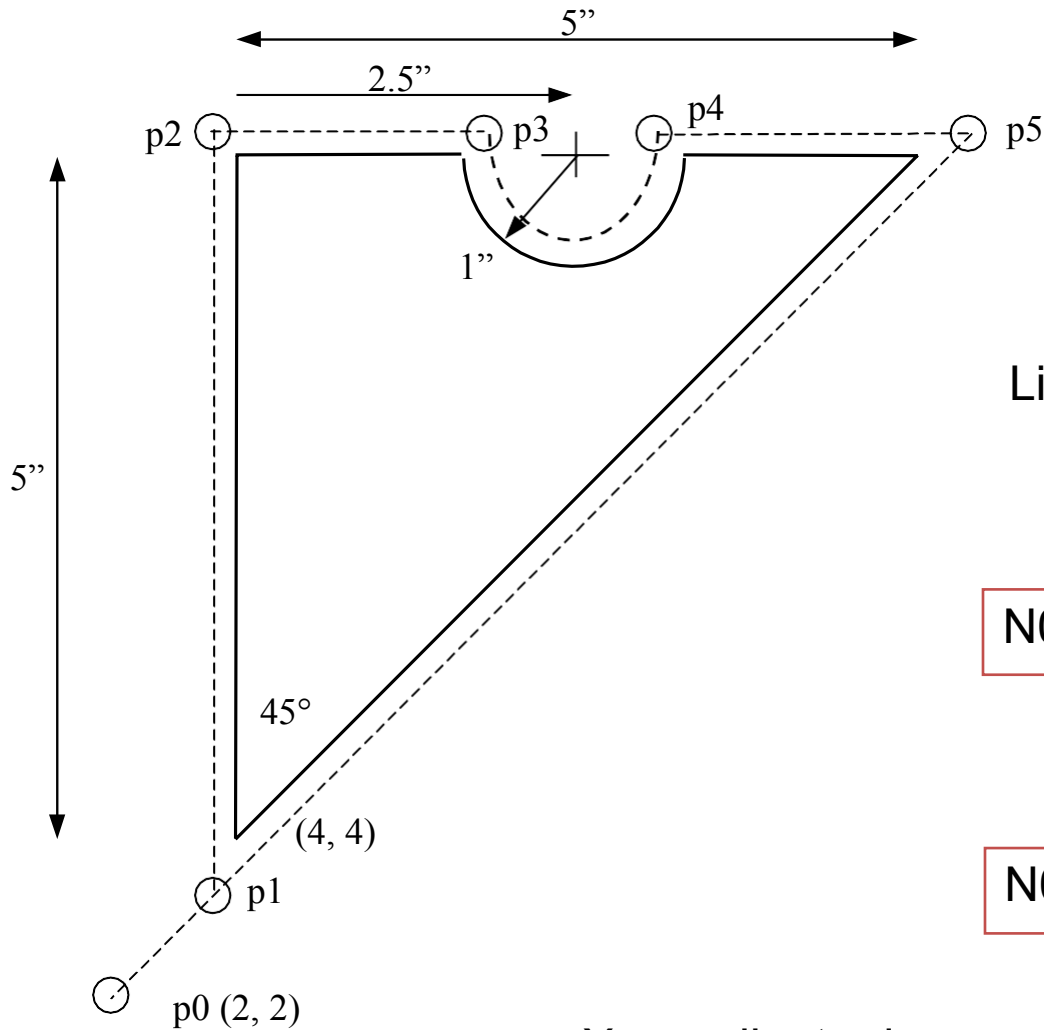

Linear interpolation

target coordinates

N040 G01 X3.875 Y9.125

or

N040 G01 Y9.125

X-coordinate does not change → no need to program it

5. Cut profile from p2 to p3

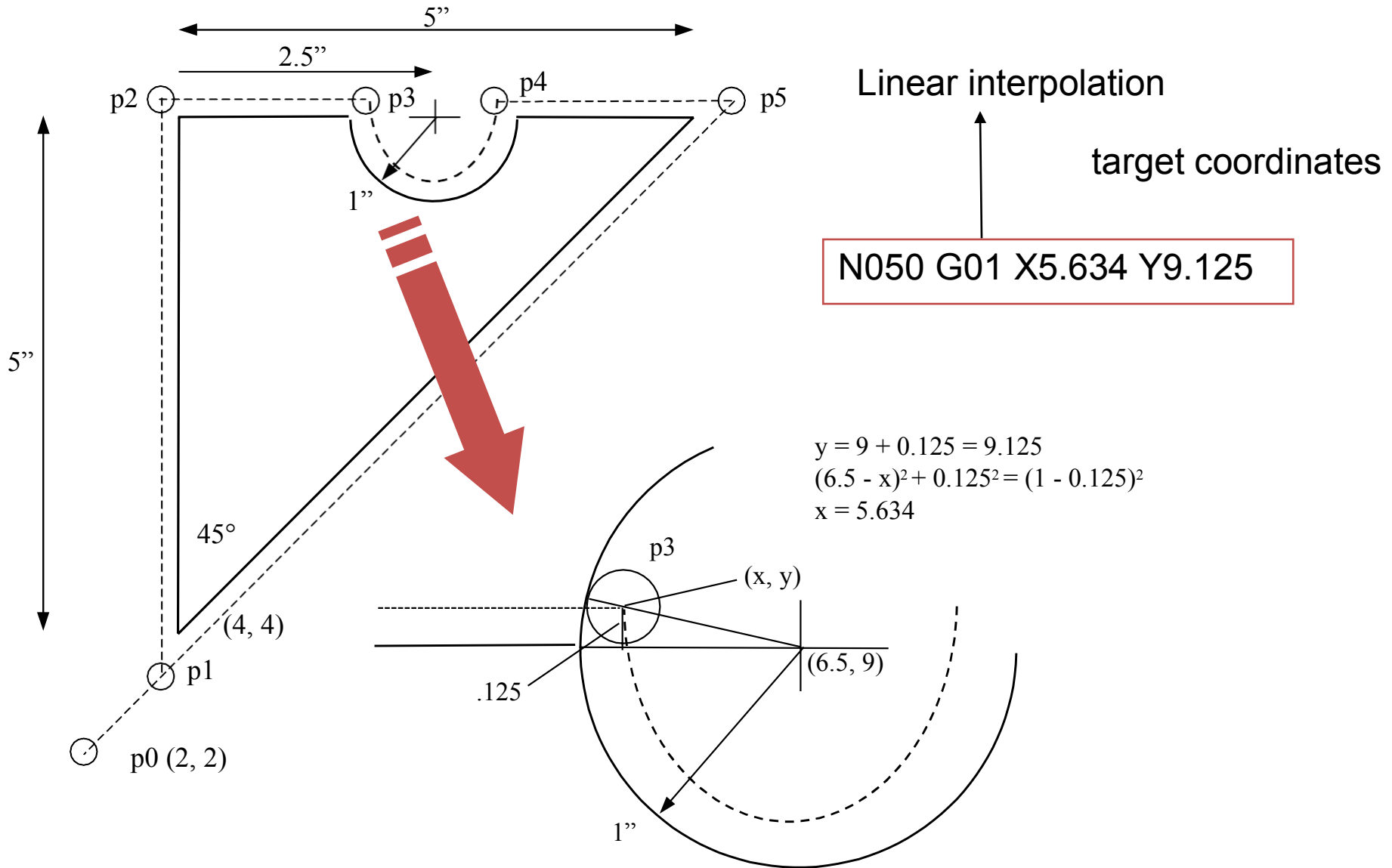

6. Cut along circle from p3 to p4

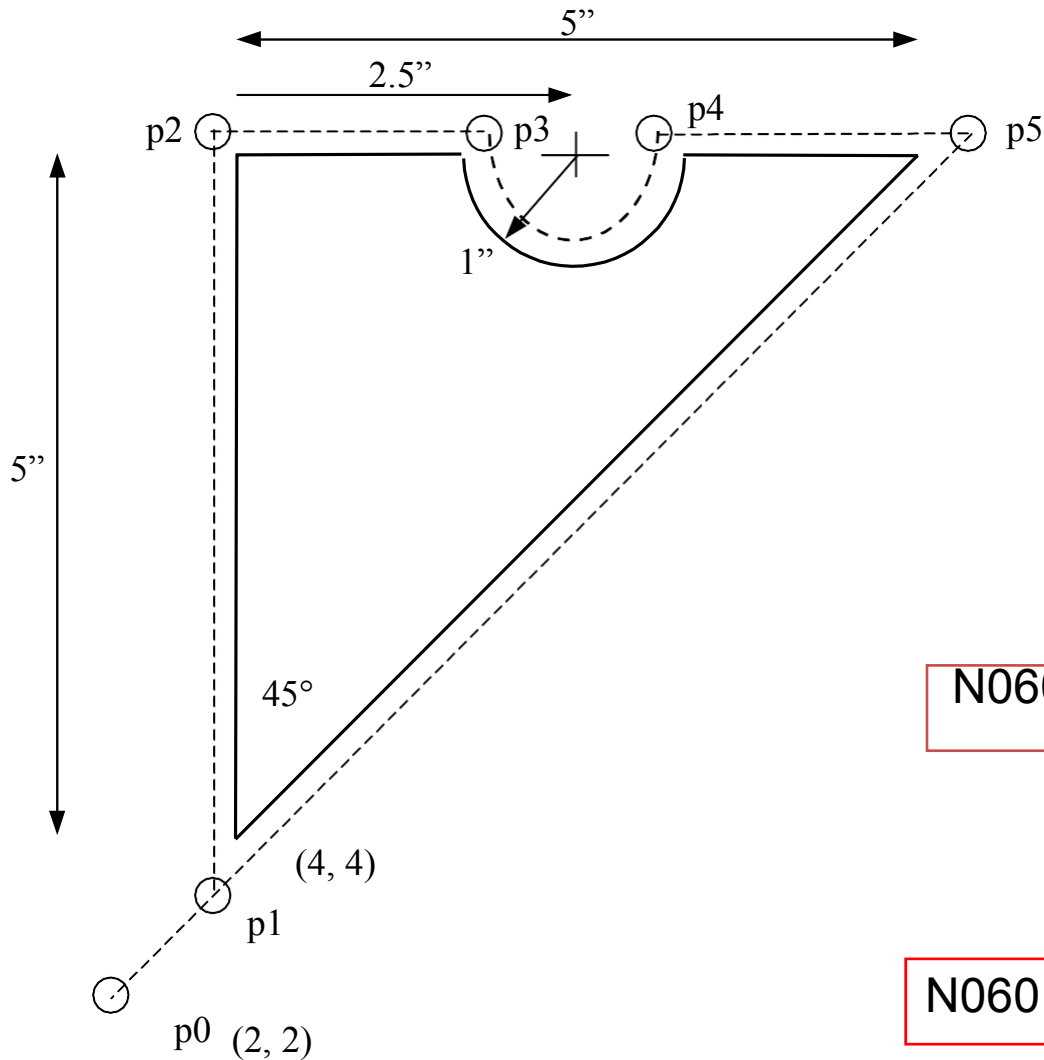

circular interpolation, CCW motion

target coordinates

```
N060 G03 X7.366 Y9.125 I6.5  
J9.0
```

coordinates of center of circle

```
N060 G03 X7.366 Y9.125 I0.866 J-0.125
```

7. Cut from p4 to p5

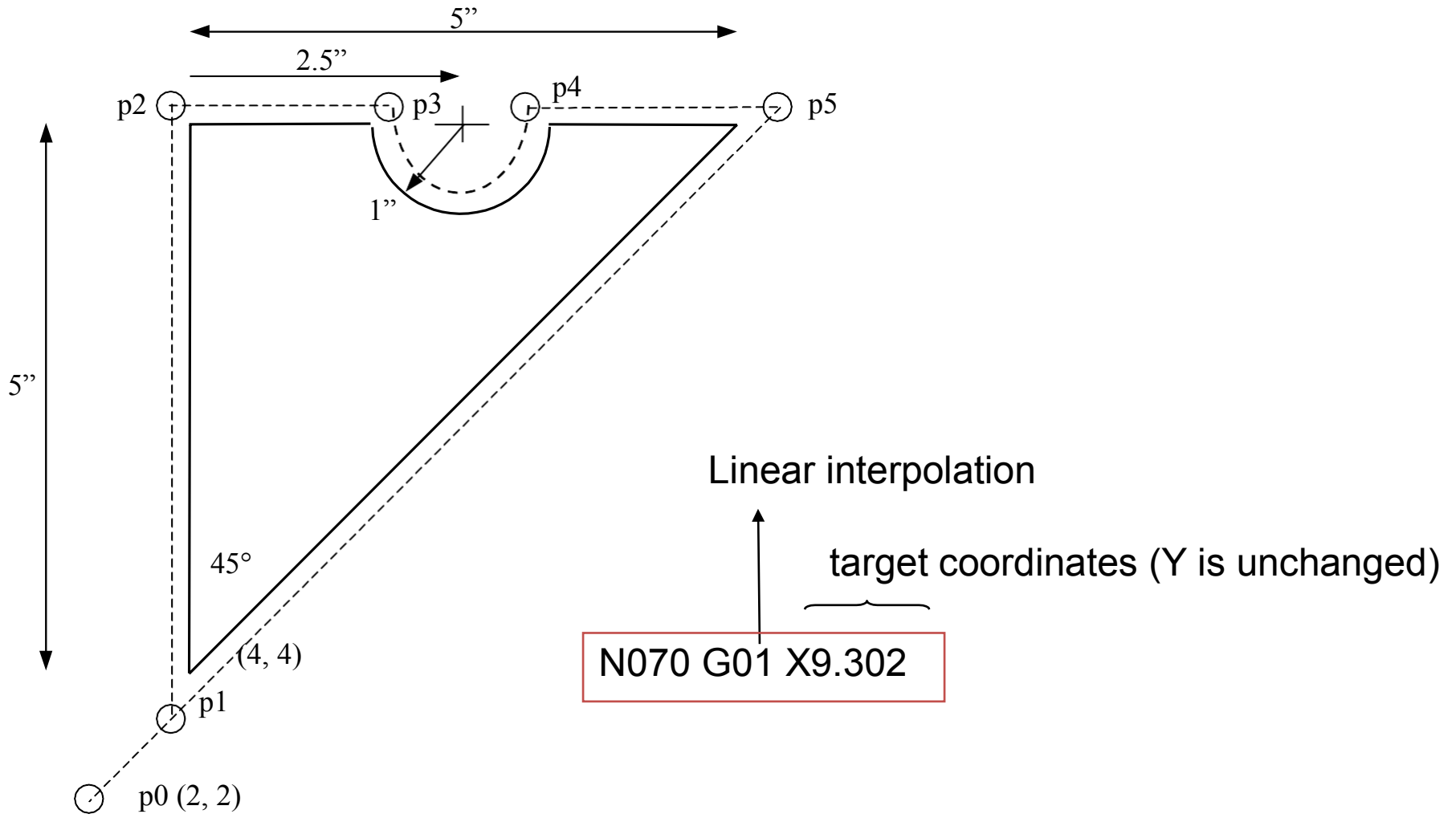

8. Cut from p5 to p1

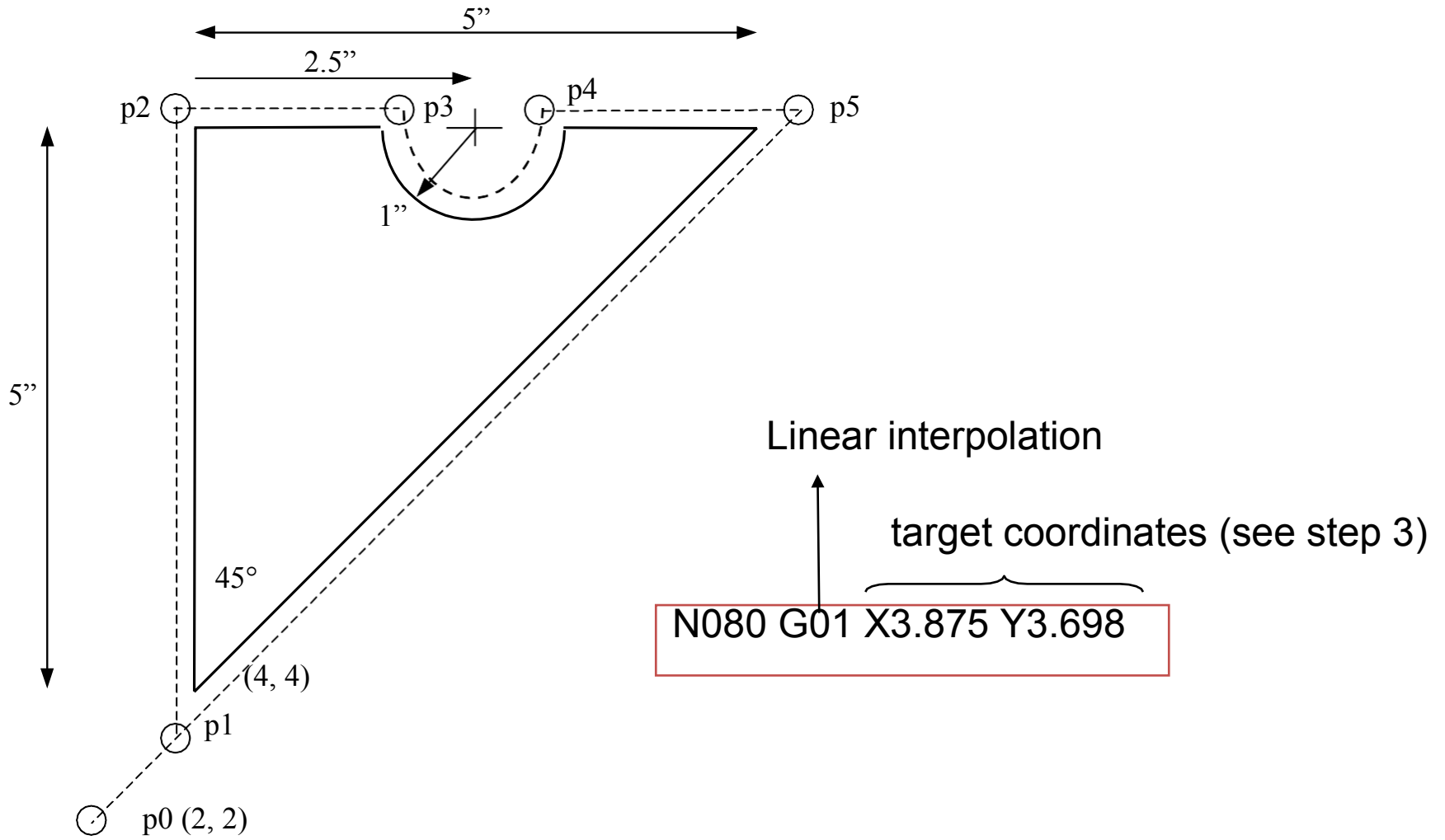

9. Return to home position, stop program

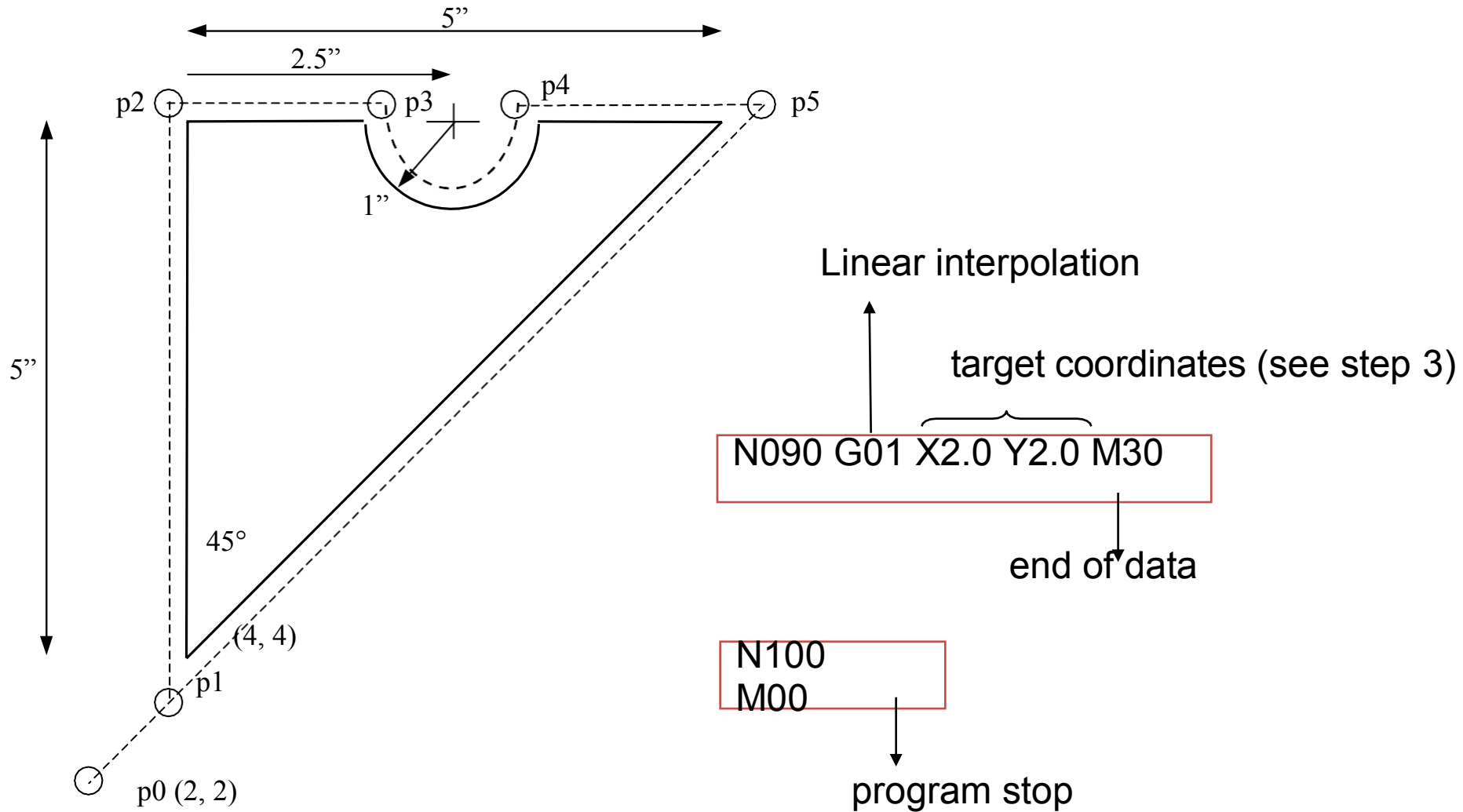

10. Complete RS-274 program

```
N010 G70 G90 G94 G97 M04  
N020 G17 G75 F6.0 S300 T1001 M08  
N030 G01 X3.875  
Y3.698 N040 G01  
X3.875 Y9.125 N050  
G01 X5.634 Y9.125  
N060 G03 X7.366 Y9.125 I0.866 J-  
0.125 N070 G01 X9.302  
N080 G01 X3.875 Y3.698  
N090 G01 X2.0 Y2.0 M30
```

Simple G Code Example CNC Lathe

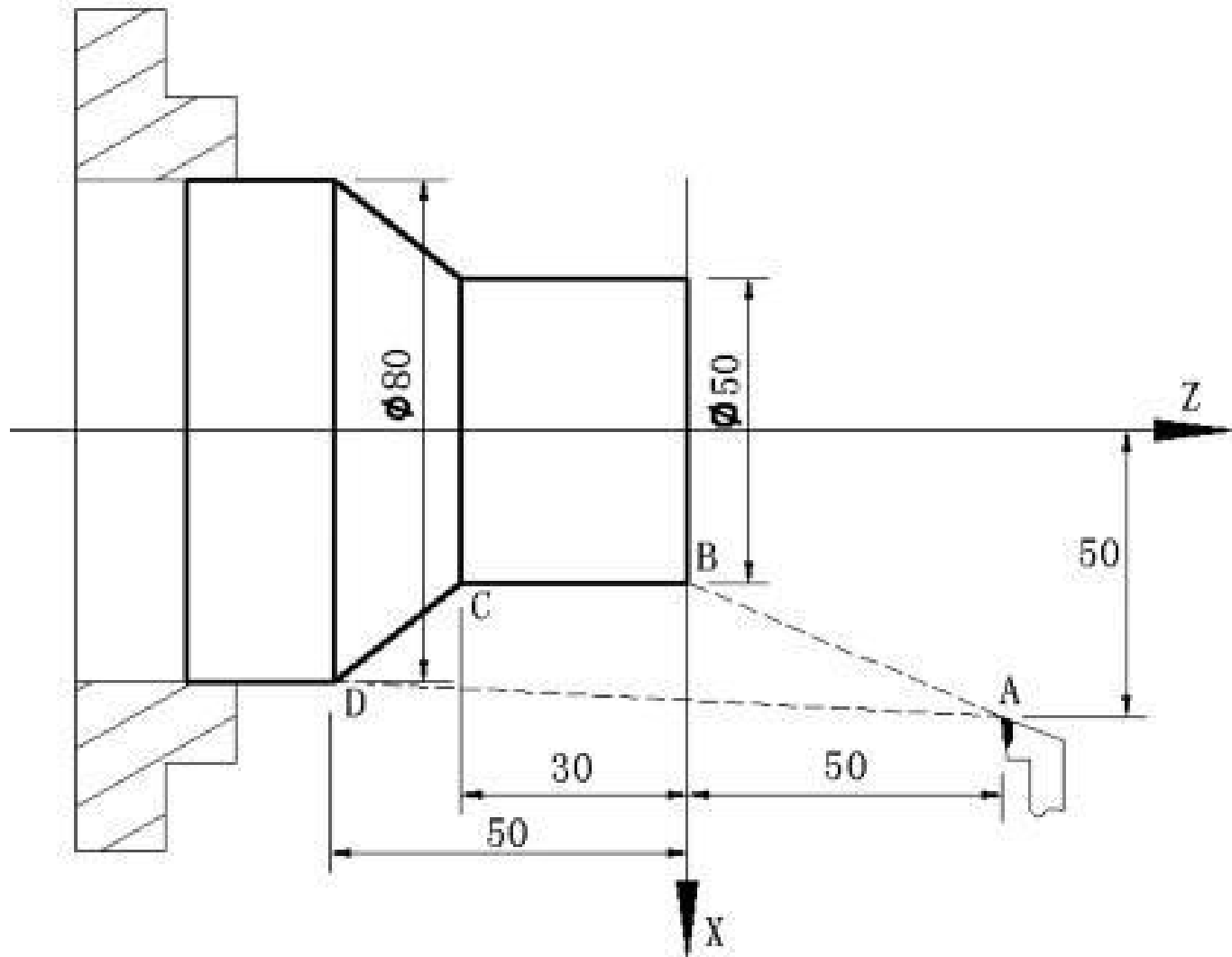

PART PROGRAM

N5 M12

N10 T0101

N15 G0 X100 Z50

N20 M3 S600

N25 M8

N30 G1 X50 Z0 F600

N40 Y-30 F200

N50 X80 Y-20 F150

N60 G0 X100 Z50

N70 T0100

N80 M5

N90 M9

N100 M13

N110 M30

Code Explanation

N5 Clamping workpiece

N10 Changing No.1 tool and executing its offset

N15 Rapidly positioning to A point

N20 Starting the spindle with 600 r/min

N25 Cooling ON

N30 Approaching B point with 600mm/min

N40 Cutting from B point to C point

N50 Cutting from C point to D point

N60 Rapidly retracting to A point

N70 Cancelling the tool offset

N80 Stopping the spindle

N90 Cooling OFF

N100 Releasing workpiece

N110 End of program, spindle stopping and Cooling OFF

CNC MILLING EXAMPLE

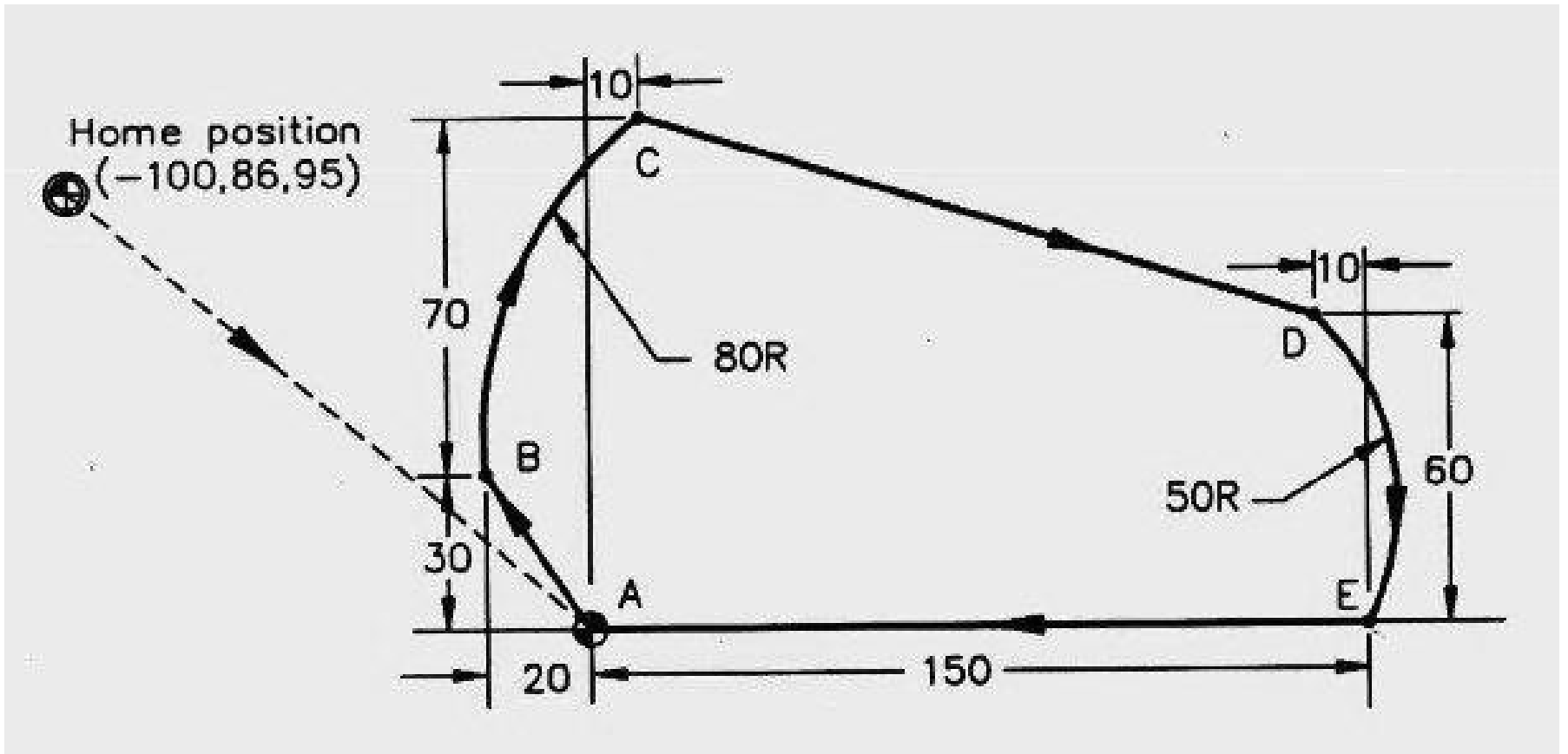

N5 G90 G71

N10 T1 M6

N15 G92 X-100 Y86 Z95

N20 G0 X0 Y0 S2500 M3

N25 Z12.5

N30 G1 Z-12.5 F150

N35 X-20 Y30

N40 G2 X10 Y100 R80

N45 G1 X140 Y60

N50 G2 X150 Y0 R50

N55 G1 X0 Y0

N60 G0 Z12.5

N65 G91 G28 Z0 M5

N70 G91 G28 X0 Y0

N75 M30

CODE EXPLANATION

N5 absolute positioning, metric unit

N10 tool change to T1

N15 define work zero point at A

N20 rapid traverse to A, spindle on (2500 RPM, CW)

N25 rapid plunge to 12.5 mm above Z0

N30 feed to Z-12.5, feed rate 150

MMPM N35 cut line AB to B

N40 cut arc BC to

C N45 cut line CD

to D N50 cut arc

DE to E N55 cut

line EA to A

N60 rapid retract to Z12.5

N65 reference point return in Z direction,

spindle off N70 reference point return in X and

Y directions N75 end of program

SAMPLE PROGRAM ON DRILLING

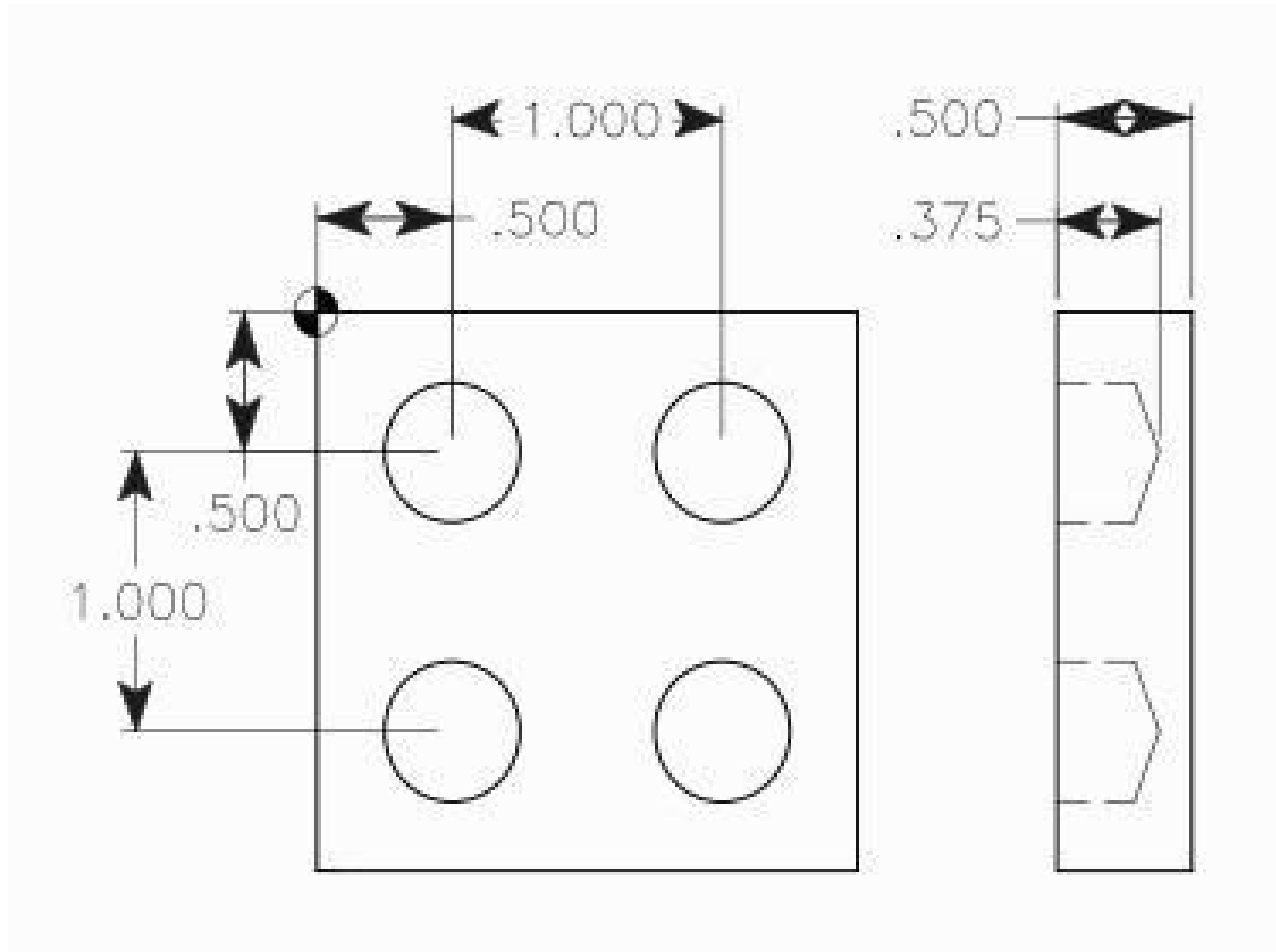

N1 T16 M06

N2 G90 G54 G00 X0.5 Y-0.5

N3 S1450 M03

N4 G43 H16 Z1. M08

N5 G81 G99 Z-0.375 R0.1 F9.

N6 X1.5

N7 Y-1.5

N8 X0.5

N9 G80 G00 Z1. M09

N10 G53 G49 Z0. M05

N11 M30

CODE EXPLANATION

N1- Tool change (M06) to tool no.16

N2- Tool rapidly moves (G00) to first drilling position X0.5 Y-0.5 while taking into account Zero-offset-no. 1 (G54)

N3- Drill starts rotating clockwise (M03) with 1450 rpm (S1450).

N4- Drill takes depth Z1. taking into account tool length compensation (G43 H16), coolant is turned on (M08).

N5- Drilling cycle (G81) parameters, drill depth (Z) and cutting feed (F) are given,

with this command first drill is made at current position (X0.5 Y-0.5).

N6- As drilling cycle continues it's work with every axis movement so next drill is

done at X1.5

N7- Third drilling hole at Y-1.5

N8- Fourth drill at X0.5

N9- Drilling cycle is cancelled (G80), Coolant is turned off (M09).

N10- Taking Machine-coordinate-system (G53) into account the drill is taken to Z0 position. Tool length compensation is cancelled (G49), cutter rotation is stopped (M05).

N11- CNC part-program is ended.

Typical PROGRAMMING - TURNING OPERATIONS

Write a part program for turning operations being carried out on a CNC turning center. Let us take an exercise:

Figure shows the final profile to be generated on a bar stock by using a CNC turning center. After studying the required part geometry and features, the main program can be written as follows.

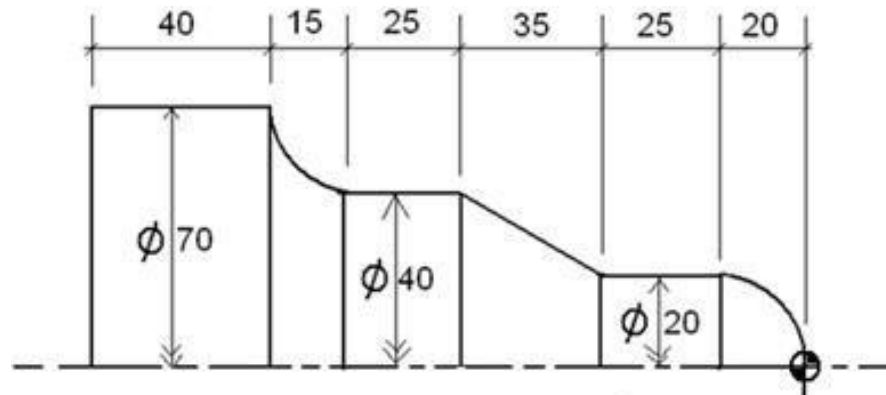

RAW MATERIAL: MS BAR OF DIAMETER 70 MM
AND LENGTH 160 MM
DIAGRAM NOT TO SCALE
ALL DIMENSIONS ARE IN MM

Figure A component to be turned.

Block 1		%
2		O0004
3	N10	G21
4	N20	G40 G90
5	N30	G54 X... Z...
6	N40	T0100 M42
7	N50	G96 S450 M03
8	N60	G00 G41 X72 Z0 T0101 M08
9	N70	G01 X0
10	N80	G00 Z5
11	N90	G42 X72
12	N100	G71 U1 R3
13	N110	G71 P120 Q190 U1 W1 F0.05
14	N120	G00 X0
15	N130	G01 Z0
16	N140	G03 X20 Z-20
17	N150	G01 Z-45
18	N160	X40 Z-80
19	N170	Z-105
20	N180	G02 X70 Z-120
21	N190	G01 X75
22	N200	G00 X100 Z20
23	N210	G70 P120 Q190 F0.03
24	N220	G00 G40 X100 Z20 T0100
25	N230	M09
26	N240	M30
27		%